

HYDRAULIC CYLINDER SERIE S-200

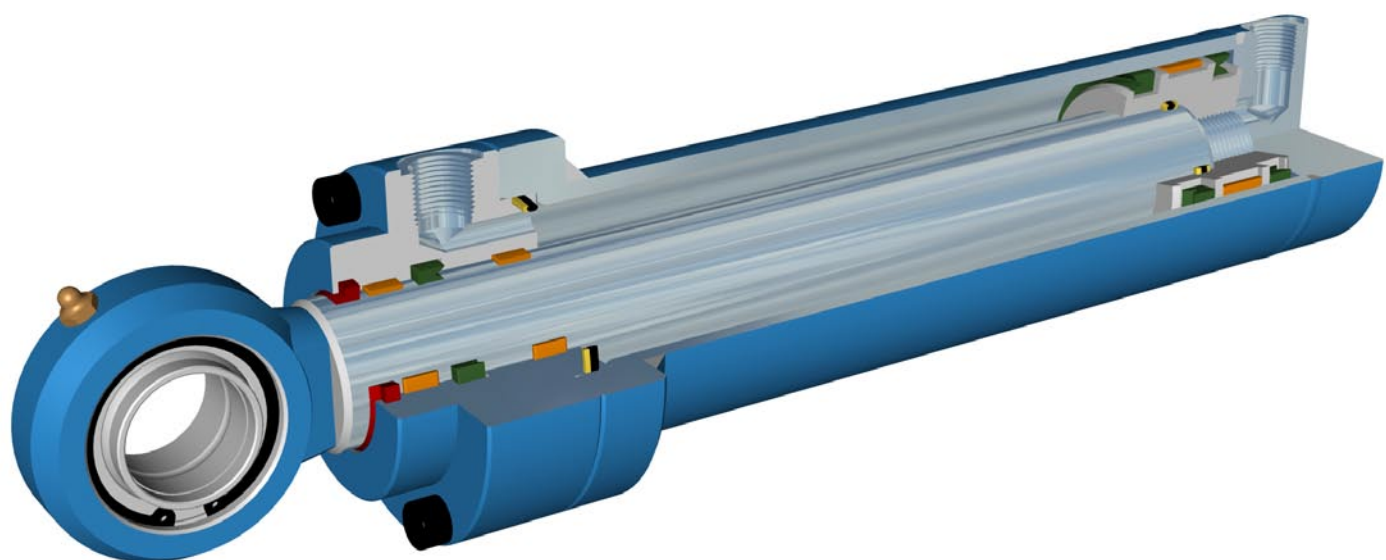

ARCOS
HYDRAULIK

ARCOS STANDARD CYLINDER – S-200

During the development of S-200, construction and choice of material has, with great concern, been set to give the cylinder the best possible qualifications for heavy use and simple maintenance. Highly set demands gives a low total cost and high availability for the user. A well tested design with a wide range of seats, makes S-200 adaptable to most applications.

S-200 is

- a double-acting hydraulic cylinder designed for industrial and mobile use in heavy, continuous operation.
- available, as standard, in cushioned design in dimensions from Ø100–Ø250 mm, and is named S-200 D.
- robust and compact. Designed to adapt to, or replace most other cylinder fabrics.
- also available, as standard, with Chesterton® seals, and is named S-200 C, and in cushioned design S-200 CD.
- designed for 25 MPa (250 Bar) continuous working pressure, intermittently to 35 MPa (350 Bar).
- cylinder series can easily be adapted to existing constructions due to the extensive range of mountings.
- available, as standard, in 12 cylinder diameters, Ø40–Ø250 mm with optional stroke lengths up to 6 000 mm.
- the right choice when quality and availability is the norm.

S-200 and S-200 C with welded eye on piston rod

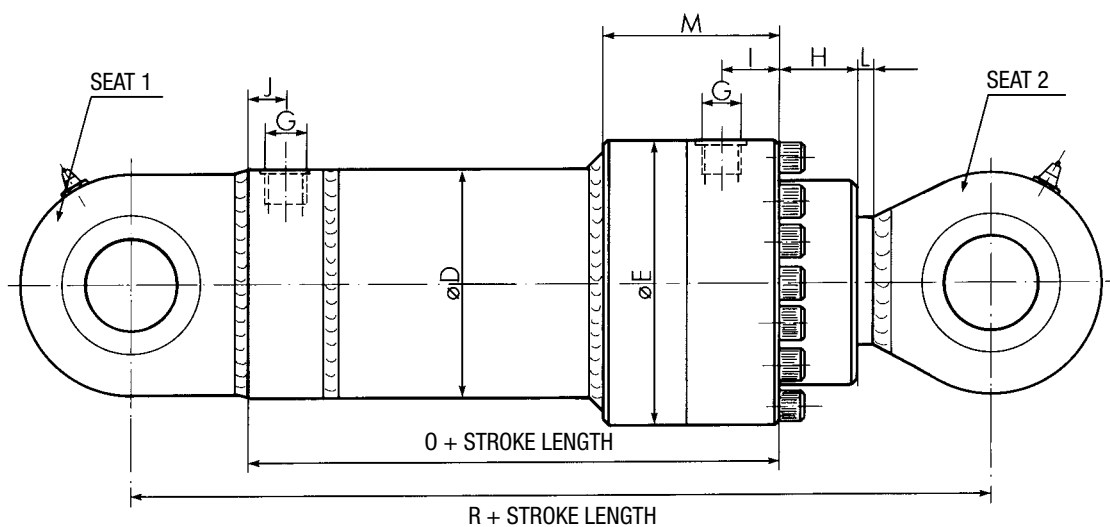

S-200				
O	R	S	T	U
100	180	209	132	93
112	205	242	147	103
125	230	277	162	113
135	260	314	172	123
170	325	400	240	170
181	366	431	261	200
195	420	515	285	230
219	471	549	309	240
230	490	585	325	250
235	540	620	340	290
268	600	733	378	310
280	630	760	400	340

S-200 C					
O	R	S	T	U	P
116	196	225	148	93	17
126	219	256	161	103	17
139	244	291	176	113	17
151	276	330	188	123	17
185	340	415	255	170	35
208	393	458	288	200	35
222	447	542	312	230	35
251	503	581	341	240	35
264	524	619	359	250	35
264	569	649	369	290	35
307	639	772	417	310	35
319	669	799	439	340	35

S-200 and S-200 C with threaded eye on piston rod

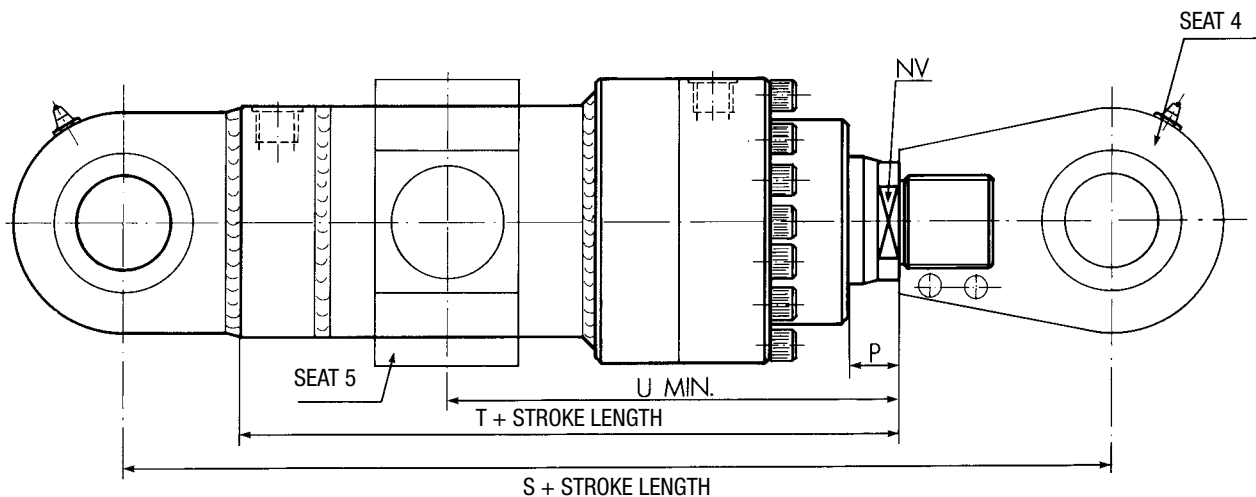

Cyl. dim	Piston rod.dim	+ area	- area	D	E	G	I	J	H	L	M	NV
40	25	12,6	7,6	50	75	R¼"	15	12	15	10	50	19
40		12,6		50	75	R¼"	15	12	15	10	50	19
50	30	19,6	12,6	60	90	R3/8"	18	15	18	10	55	24
50		19,6		60	90	R3/8"	18	15	18	10	55	
63	40	31,2	18,6	73	100	R½"	20	17	20	10	63	32
63		31,2		73	100	R½"	20	17	20	10	63	32
80	50	50,2	30,6	92	125	R½"	20	17	20	10	63	41
80		50,2		92	125	R½"	20	17	20	10	63	
100	50	78,5	59	115	150	R¾"	30	25	35	10	87	41
100	70	78,5	40	115	150	R¾"	30	25	35	10	87	55
125	70	122,7	84,2	140	180	R¾"	40	25	45	10	103	55
125	90	122,7	59,1	140	180	R¾"	40	25	45	10	103	75
140	90	153,9	90,3	160	195	R¾"	40	30	55	10	125	75
140	100	153,9	75,4	160	195	R¾"	40	30	55	10	125	85
160	90	201	137,4	180	217	R1"	46	33	55	17	120	75
160	110	201	106	180	217	R1"	46	33	55	17	120	95
180	90	254,3	190,8	203	240	R1"	43	35	60	20	130	75
180	110	254,3	159,4	203	240	R1"	43	35	60	20	130	95
200	110	314,1	219,1	229	276	R1"	45	35	70	15	140	95
200	140	314,1	160,2	229	276	R1"	45	35	70	15	140	115
220	140	380,1	226	267	300	R1¼"	58	40	75	17	158	115
220	160	380,1	179,1	267	300	R1¼"	58	40	75	17	158	130
250	160	490,8	290	298	320	R1¼"	70	40	85	15	168	130
250	180	490,8	236,3	298	320	R1¼"	70	40	85	15	168	155

S-200 D and S-200 CD with threaded eye on piston rod

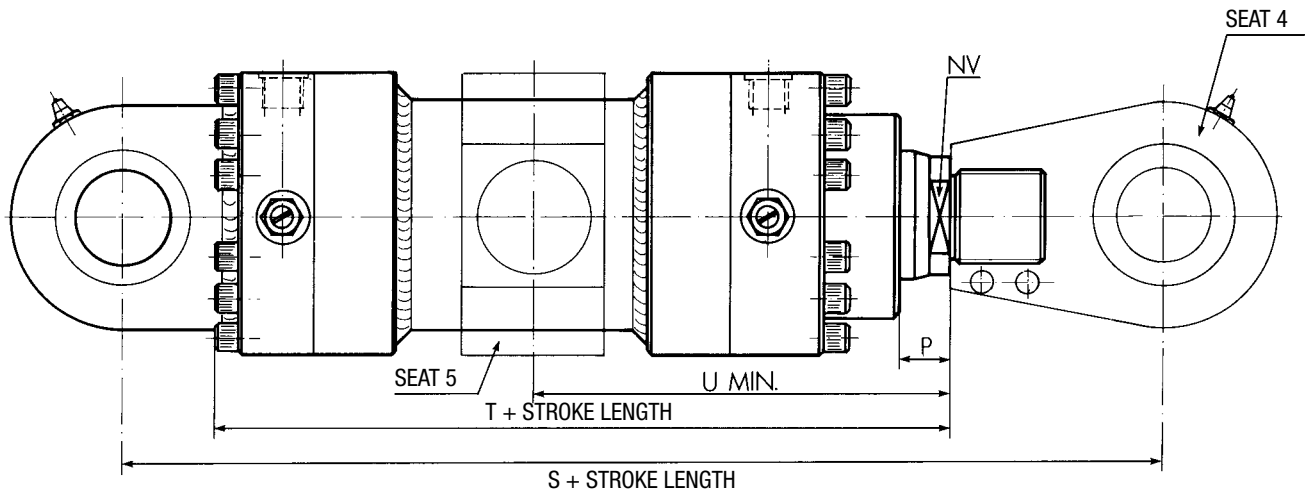

Cyl. dim	Piston rod. dim	+ area	- area	D	E	G	I	J	H	L	M	NV	P	O	R	S	T	U
100	50	78,5	59	115	150	R¾"	30	25	35	10	87	41	35	200	355	430	282	170
100	70	78,5	40	115	150	R¾"	30	25	35	10	87	55	35	200	355	430	282	170
125	70	122,7	84,2	140	180	R¾"	40	25	45	10	103	55	35	223	408	473	315	200
125	90	122,7	59,1	140	180	R¾"	40	25	45	10	103	75	35	223	408	473	315	200
140	90	153,9	90,3	160	195	R¾"	40	30	55	10	125	75	35	235	460	555	341	230
140	100	153,9	75,4	160	195	R¾"	40	30	55	10	125	85	35	235	460	555	341	230
160	90	201	137,4	180	217	R1"	46	33	55	17	120	75	35	265	517	595	371	240
160	110	201	106	180	217	R1"	46	33	55	17	120	95	35	265	517	595	371	240
180	90	254,3	190,8	203	240	R1"	43	35	60	20	130	75	35	274	534	629	385	250
180	110	254,3	159,4	203	240	R1"	43	35	60	20	130	95	35	274	534	629	385	250
200	110	314,1	219,1	229	276	R1"	45	35	70	15	140	95	35	279	584	664	404	290
200	140	314,1	160,2	229	276	R1"	45	35	70	15	140	115	35	279	584	664	404	290
220	140	380,1	226	267	300	R1¼"	58	40	75	17	158	115	35	312	644	777	442	310
220	160	380,1	179,1	267	300	R1¼"	58	40	75	17	158	130	35	312	644	777	442	310
250	160	490,8	290	298	320	R1¼"	70	40	85	15	168	130	35	324	674	804	464	340
250	180	490,8	236,3	298	320	R1¼"	70	40	85	15	168	155	35	324	674	804	464	340

S-200 D and S-200 CD with link-layer and welded eye on piston rod

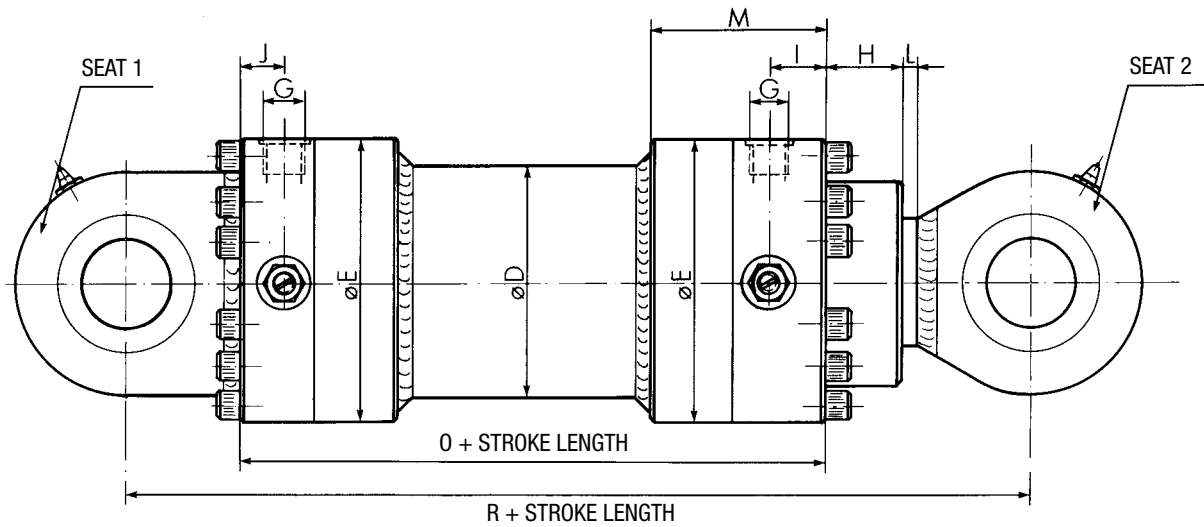

Cyl. dim	Piston rod. dim	+ area	- area	D	E	G	I	J	H	L	M	NV	P	O	R	S	T	U
100	50	78,5	59	115	150	R¾"	30	25	35	10	87	41	35	200	355	430	282	170
100	70	78,5	40	115	150	R¾"	30	25	35	10	87	55	35	200	355	430	282	170
125	70	122,7	84,2	140	180	R¾"	40	25	45	10	103	55	35	223	408	473	315	200
125	90	122,7	59,1	140	180	R¾"	40	25	45	10	103	75	35	223	408	473	315	200
140	90	153,9	90,3	160	195	R¾"	40	30	55	10	125	75	35	235	460	555	341	230
140	100	153,9	75,4	160	195	R¾"	40	30	55	10	125	85	35	235	460	555	341	230
160	90	201	137,4	180	217	R1"	46	33	55	17	120	75	35	265	517	595	371	240
160	110	201	106	180	217	R1"	46	33	55	17	120	95	35	265	517	595	371	240
180	90	254,3	190,8	203	240	R1"	43	35	60	20	130	75	35	274	534	629	385	250
180	110	254,3	159,4	203	240	R1"	43	35	60	20	130	95	35	274	534	629	385	250
200	110	314,1	219,1	229	276	R1"	45	35	70	15	140	95	35	279	584	664	404	290
200	140	314,1	160,2	229	276	R1"	45	35	70	15	140	115	35	279	584	664	404	290
220	140	380,1	226	267	300	R1¼"	58	40	75	17	158	115	35	312	644	777	442	310
220	160	380,1	179,1	267	300	R1¼"	58	40	75	17	158	130	35	312	644	777	442	310
250	160	490,8	290	298	320	R1¼"	70	40	85	15	168	130	35	324	674	804	464	340
250	180	490,8	236,3	298	320	R1¼"	70	40	85	15	168	155	35	324	674	804	464	340

Seat 1, 2 and 4 with threaded eye on piston rod. S-200 D and S-200 CD

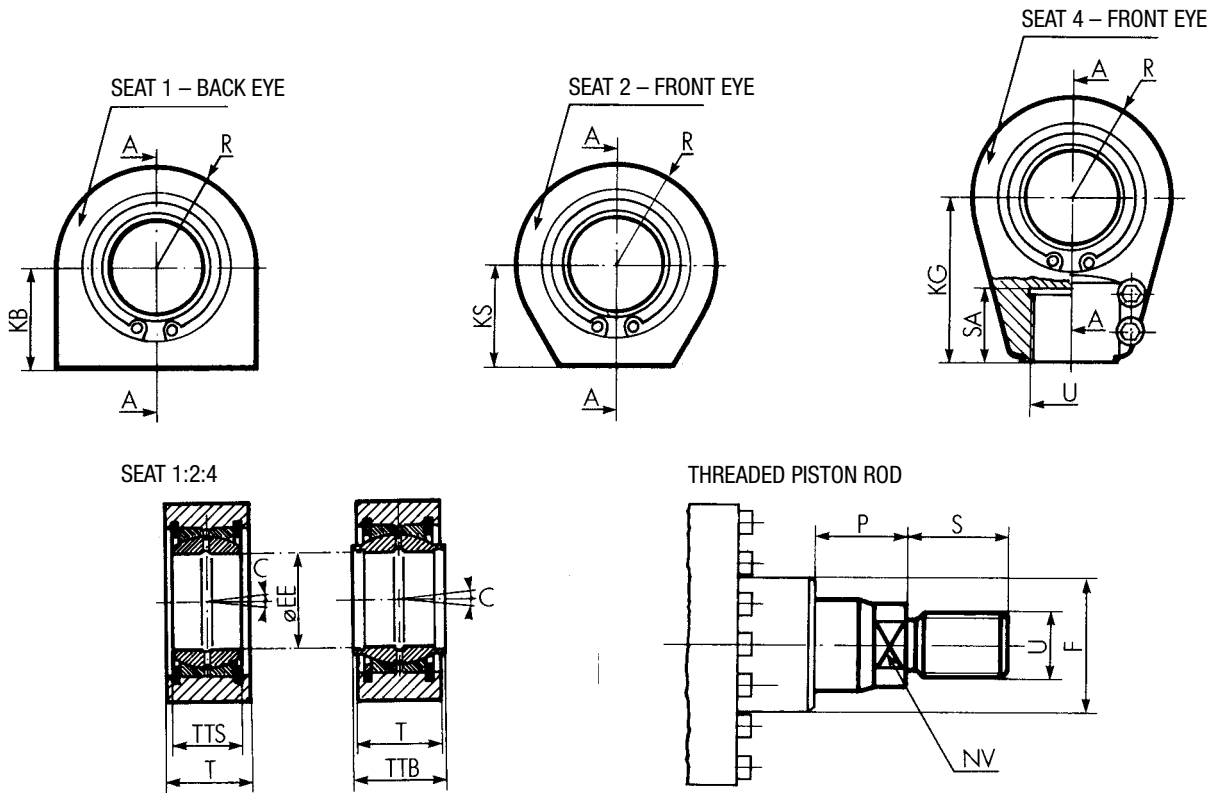

Cyl.	R	KB	KS	T	H12 TT S	H12 TT B	H7 EE	°C	KG	SA
40	25	25	30	18	-	20	20	4°	52	23
50	30	30	35	23	-	25	25	4°	65	29
63	35	35	40	30	-	32	32	4°	80	37
80	45	45	50	35	-	40	40	4°	97	46
100	55	55	55	40	35	43	50	6°	105	46
125	65	65	65	40	35	43	50	6°	105	46
140	75	80	80	60	49	65	70	6°	150	66
160	85	90	90	60	49	65	70	6°	150	66
180	95	90	90	70	55	74	80	6°	170	81
200	105	110	110	70	55	74	80	6°	170	81
220	115	120	120	90	70	100	100	7°	235	111
250	125	125	125	90	70	100	100	7°	235	111

S	P	U	NV	F
22	17	M16x1,5	19	42
28	17	M20x1,5	24	50
35	17	M27x2	32	70
45	17	M33x2	41	85
45	35	M45x1,5	41 55	106
45	35	M45x1,5	55 75	132
65	35	M65x1,5	75 85	140
65	35	M65x1,5	75 95	160
80	35	M80x2	75 95	180
80	35	M80x2	95 115	200
110	35	M110x2	115 130	220
110	35	M110x2	130 155	250

Seat 3 and 5 with threaded eye on piston rod. S-200 D and S-200 CD

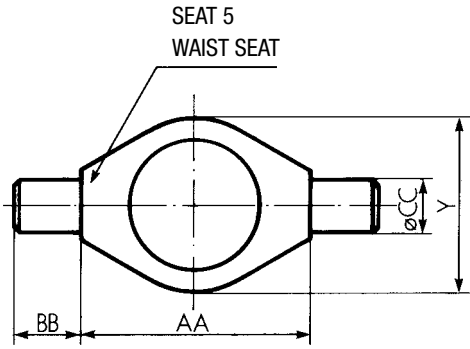
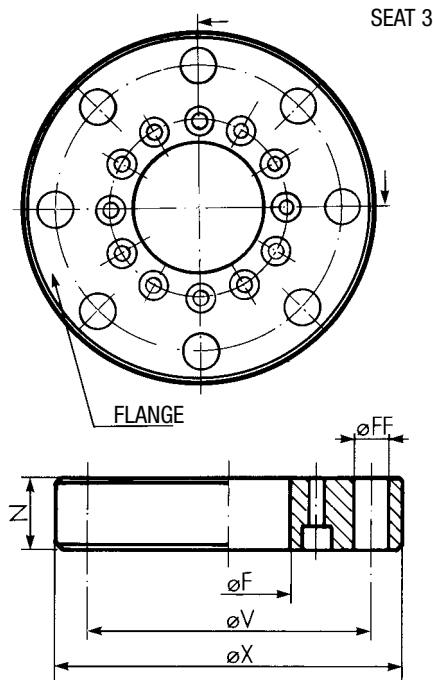

Seat 3					
Cyl.	F	N	V	X	H3
40	42	12	106	125	9
50	50	14	126	150	11
63	70	16	145	175	13,5
80	85	16	165	200	17,5
100	106	30	200	240	22
125	132	40	235	285	22
140	140	50	260	310	22
160	160	50	280	330	22
180	180	55	330	380	22
200	200	60	340	390	26
220	220	70	380	440	26
250	250	80	420	500	33

Seat 5				
H12	f8			
AA	BB	CC	Y	Z
90	16	20	70	30
105	20	25	85	35
120	25	32	95	40
135	32	40	120	50
160	40	50	150	70
195	50	63	180	80
220	55	70	195	80
240	63	80	217	100
270	70	90	240	100
295	80	100	270	125
350	90	110	310	125
370	100	125	340	140

Seat 6 with threaded eye on piston rod. S-200 D and S-200 CD

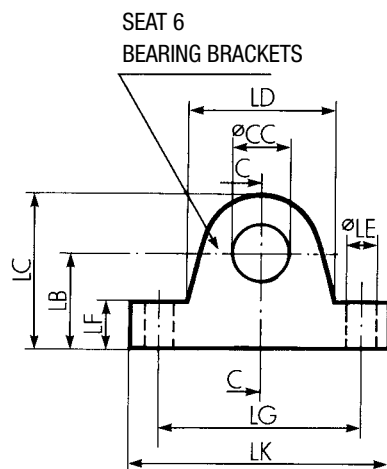

AXLE SETS FOR SEATS 1:2:4:6

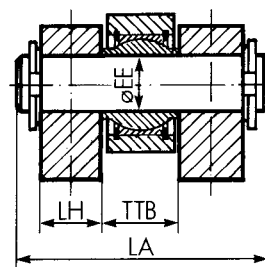

H7	max.										
EE	LA	LB	LC	LD	LE	LF	LG	LH	LK		BINDINGSCREW
20	75	45	65	45	9	20	65	20	85		4xM8
25	90	50	75	60	11	25	85	25	110		4xM10
32	105	60	90	70	11	30	100	30	130		4xM10
40	125	70	105	90	13	35	125	35	160		4xM12
50	140	85	130	115	17	40	155	40	195		4xM16
50		100	155	140	19	50	180	50	220		4xM18
70	200	110	170	150	17	60	190	60	230		8xM16
70		120	190	170	19	60	210	60	250		8xM18
80		130	210	190	22	70	240	70	290		8xM20
80		150	240	220	26	70	270	80	320		8xM24
100		170	270	240	26	80	300	90	360		8xM24
100		185	295	270	26	80	330	100	390		8xM24



Teknikergatan 5
SE-781 70 Borlänge
Sweden

Tel. +46 (0)243-820 75
Fax +46(0)243-102 82
www.arcos.se